

■ TECHNICAL NOTES

1-1. Operating Principle

By externally applying a voltage below a certain voltage to the boundary, higher charges can be accumulated. Charge and discharge of capacitor utilize adsorption and desorption of ions to the ionic adsorption layer (electric double layer) formed on the electrode surface of the activated carbon used for electrodes. The capacitors have electric charges oriented at the very short distance on boundary of electrolyte and electrodes what is called the "electric double layer capacitor."

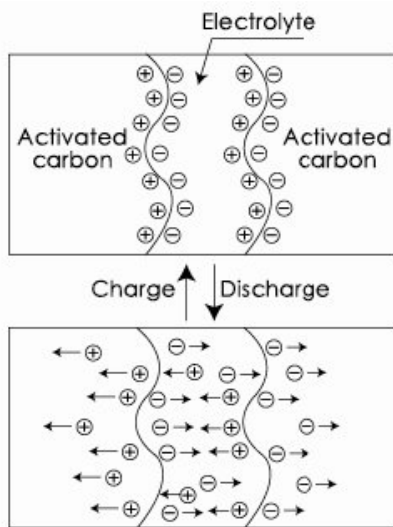

Fig. 1

1-2. Advantages and Disadvantages of Electric Double Layer Capacitor

EDLC differs from rechargeable batteries, not causing chemical reaction, with surface of activated carbon with energy accumulation by ionic physical attachment only, therefore it holds the characteristics stated below:

■ Advantages

- (1) Small size and capacitance in farads (F) available by utilizing the activated carbon electrode with a large surface area
- (2) With low degradation, million cycles of charge-discharge and long life is possible
- (3) With a high power density, rapid (high current) charge-discharge is possible
- (4) Ease of maintenance
- (5) Environment-friendly without using heavy metal for its structure material

■ Disadvantages

- (1) Low energy density
- (2) Series connection is required when used with a low resistance of voltage at a high voltage
- (3) Cannot be used in AC circuits due to high internal resistance unlike aluminum electrolytic capacitors

1-1、工作原理

在额定电压范围内，通过外部施加电压使得电荷在界面聚集。电容的充放电通过在活性炭电极表面形成的离子吸附界面（双电层）处离子的吸附和脱附来实现。利用电解液和电极的界面之间相隔的距离极其短，电荷在界面处集中排列从而形成物理储电的电容，称为“双电层电容”。



图. 1

1-2、EDLC 的特点

EDLC 不同于二次电池，不发生化学反应，利用活性炭表面离子的物理吸附实现储能，因此具有以下特征：

■ 优势：

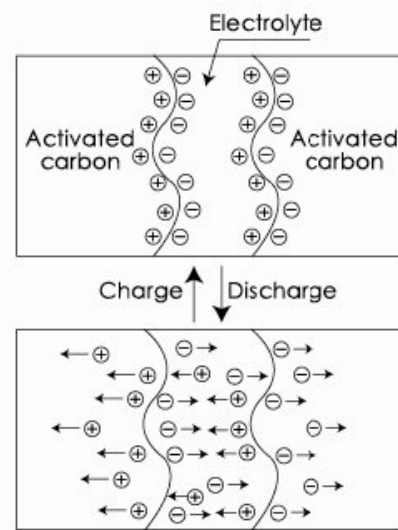
- (1) 利用活性炭的比表面获得小体积和大容量
- (2) EDLC 劣化缓慢，具有长寿命和上百万次的循环寿命
- (3) 具有高输出功率特性，实现快速充放电
- (4) 易于维护
- (5) 构成材料中没有使用重金属元素，环境友好

■ 劣势

- (1) 低能量密度
- (2) 由于单体电压低，在高电压使用时需要多只串联。
- (3) 由于其内阻相对铝电解电容器较高，不能用在 AC 电路中。

2. Description of life expectancy

Generally, the life of Electric Double Layer Capacitors is largely affected by the ambient temperature. The expected life is approximated by the equation as shown below:

$$L = L_0 \times \left(\frac{T_0 - T}{10} \right)$$

Where:

- L: Expected lifetime at temperature T
- L₀: Lifetime at temperature T₀
- T: Expected working temperature
- T₀: Upper category temperature

Note that the above equation does not cover charge and discharge. In the case of charge and discharge, heat generation occurs inside a capacitor; the temperature rise by this heat generation must also be considered

3. Handling Precautions and Guidelines

For safety application, please contact company directly for any technical specifications, handling precautions and guidelines critical to application.

3-1. Precautions

(1) Prohibition of disassembly

The disassembling may generate internal short circuit in the cell, which may cause gassing, leakage, explosion, or other problems. Electrolyte is harmful: In case the electrolyte comes into contact with the skin, or eyes, physicians shall flush the electrolyte immediately with fresh water and medical advice is to be sought.

(2) Prohibition of dumping of cells into fire

These may cause explosion of the cells, which is very dangerous and is prohibited.

(3) Prohibition of cells immersion into liquid.

The cells shall never be soaked with liquids such as water, seawater, drinks such as juices, coffee or others.

(4) Prohibition of use of damaged cells.

The cells might be damaged during shipping by shock. If any abnormal features of the cells are found such as damages in the cell package, smelling of an electrolyte, an electrolyte leakage and others, the cells shall never be used any more. The Cells with a smell of the electrolyte or a leakage shall be placed away from fire to avoid firing or explosion.

2、寿命估算

一般来说，环境温度对 EDLC 的寿命影响很大。其理论估算寿命的计算公式参照如下：

$$L = L_0 \times \left(\frac{T_0 - T}{10} \right)$$

其中：

- L: T 温度下理论寿命
- L₀: 最高额定工作温度的工作寿命
- T: 实际工作温度
- T₀: 最高额定工作温度

以上公式未考虑电容的充放电的情况。电容充放电产生会在电容内部热产生热量，这就需要考虑电容内部的温升。

3、使用注意事项和使用手册

为了确保安全，当设计的设备需使用电容时，请与公司联系咨询电容的技术规格以及使用要求。

3-1、注意事项

(1) 禁止拆卸

拆卸电容器可能产生内部短路，导致产气，电解液泄漏。电解液有害，如果电解液接触皮肤或者眼睛，应该立即用清水冲洗并且寻求医生的治疗。

(2) 禁止将电容器投入火中

将电容器投入火中可能导致爆炸，这种行为是非常危险，是被禁止的。

(3) 禁止将电容器浸没于液体中

电容器不允许被浸泡在液体中，例如水，盐水，饮料例如果汁，咖啡或者其它。

(4) 禁止使用已经损坏的电容器

如果使用前发现电容的外包装破裂，闻到电解液的气味，电解液泄漏或者其它非正常情况，请勿继续使用。

3-2. Handling Guidelines

(1) It is not suitable that cell is used under such conditions:

AC circuit and wave filtering.

(2) Voltage

Work voltage of cell should not exceed Max. work voltage of cell during using. Otherwise, will shorten shelf life, even cause swelling, leakage or crack.

(3) Polarity

Please check the polarity before using. If working under reverse polarity, cell will not only shorten shelf life, but also heavy damage, such as swelling, electrolyte leakage etc.

(4) Environment

Work temperature will have an influence on life of cell. As usual, higher work temperature will shorten life. So, it is better that cell works under as possible as low environmental temperature.

Work temperature of cell should consider internal environmental temperature in the unit and temperature rise when cell works.

(5) IR drop

When main power sources shut down, cell will change into work mode from failure mode, at the same time, OCV will decrease due to IR drop. So please choose proper product type according to impedance specified in product datasheet and applied current.

(6) Cells in series connection

When cells in series connection for higher work voltage, it should be assured that work voltage of any single cell must not exceed Max. work voltage of single cell, otherwise, will shorten shelf life, even cause swelling, leakage or crack.

(7) Soldering

Heat shock will decrease electric performance of cell, even cause swelling, leakage or crack.

Manual soldering temperature should not exceed 350°C, soldering time should not exceed 4s. Wave soldering temperature should not exceed 260°C, soldering time should not exceed 5s, while preheating temperature should be limited to less than 100°C and maximum preheating time of 60 seconds for PC boards 0.8mm or thicker.

Unless the EDLC is specifically rated to withstand reflow soldering temperature, please don't use reflow soldering, infrared heating and air heating methods on the EDLC.

3-2、使用指导

(1) 不可用于以下场合：

不能用于交流线路中；不能用于滤波。

(2) 电压

使用过程中，电容器的工作电压不能超过其最大工作电压。否则，将缩短其使用寿命，甚至导致气胀，泄露，或者开裂。

(3) 极性

使用前一定要检查电容器的极性，电容长时间在相反的极性下工作，不仅会缩短其使用寿命，而且可能导致严重的损毁，例如导致气胀，电解液泄漏等。

(4) 环境

电容的寿命会受到工作温度的影响，一般而言，电容的工作环境温度越高，其寿命越短。因此，应使电容的工作温度在最大容许温度下尽可能地降低。

工作温度应该同时考虑环境温度以及工作时电容内部产生的温升。

(5) IR 压降

在主电源关闭时，电容将从电源失效检验模式转为后备电源工作模式，此时由于瞬间启动电流及电容内阻将导致开路电压下降。请根据相关产品介绍中所列出的阻抗和使用电流确定正确的产品型号。

(6) 电容串联

当多个单体电容串联使用以提高工作电压时，必须确保每只单体电容两端的电压不超过其最大工作电压，否则，将缩短其使用寿命，甚至导致气胀，泄露，或者开裂。

(7) 焊接

热冲击会影响电容的电性能，甚至会导致电容的鼓气、漏液以及开裂。

手工焊的温度建议低于 350°C，焊接持续时间少于 4S。波峰焊的温度建议低于 260°C，焊接持续时间少于 5S。其中预热温度应低于 100°C，最多给 PCB 预热 60S，浸锡达 0.8mm 或更厚。

除非 EDLC 有明确的额定耐回流焊接温度，否则不应使用 EDLC 使用回流焊，而应使用红外线或空气加热方式。